

Wahl-Fingerzylinder (mm)
Zwei-Rollenmaß (spielfrei) 10.502
- (obere) 10.407
Zahndickenstufte (untere) 10.257
7.675
Höhe über des Zahne (mm)

The eAssistant CAD plugin for Inventor

The intelligent connection of calculation and CAD for the web-based calculation software eAssistant with Autodesk Inventor



GWJ Technology GmbH

Rebenring 31

D - 38106 Braunschweig, Germany

Phone: +49 (0) 531 129399-0

Fax: +49 (0) 531 129399-29

Email: info@gwj.de

1. System requirements

To run the CAD plugin, you have to install „Microsoft .NET Framework“ on your system. Click the following link to download and to install .NET Framework:

<http://www.microsoft.com/downloads/search.aspx?displaylang=en>

Click on the menu item „Development Ressources“ on the left side and download the file „.NET Framework Version 2.0 Redistributable Package (x86)“.

2. Installation

Please start the installation file and follow the instructions. The CAD plugin will be installed on your system. Once the plugin is installed, start Autodesk Inventor and open a new part. Now the top Autodesk Inventor menu bar provides the entry „eAssistant“.

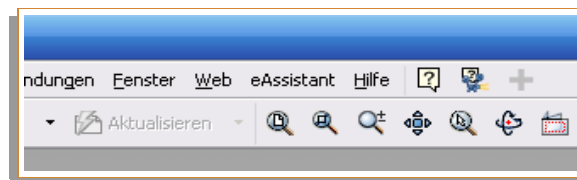

3. Start

Click on „eAssistant“ to use all functions of the plugin in Autodesk Inventor.

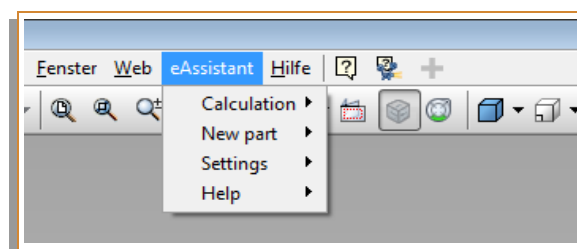

4. Program scope

At the moment, the following features can be created in Autodesk Inventor on the basis of the calculated eAssistant data:

- cylindrical and helical gears (outer and inner gears)
- shaft geometry (cylinder outside and inside, cones outside and inside)

Zwei-Rollenmaße (mm)			
(spielfrei)	10.502		
(obere)	10.407		
(untere)	10.257		
Zahndickenstufen			
	7.675		
Höhe über der Nabe (mm)			

Use the eAssistant to accomplish a calculation. Click on the button **CAD => Output for CAD-PlugIn** in the top menu bar of the eAssistant.

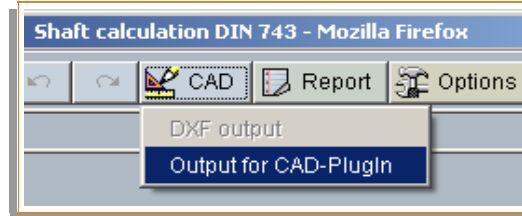

Click on the menu item „New part“ in the plugin and select the corresponding element. Now the 3D model is created.

Settings

Click on the menu item **Settings => User data**. Here you can enter your username and your password. You need an account to use all eAssistant calculation modules.

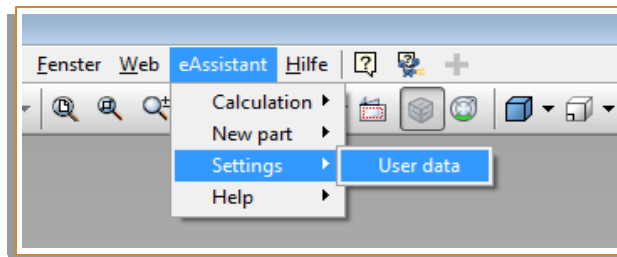

In case you do not have an account to the eAssistant, please visit the following web site www.eAssistant.eu to register for a free test account. Click on the button „Request access data“ to get to the eAssistant web site as well. The account provides a time credit of five hours to test the eAssistant without any charges or obligation. Are the five hours expired, the test account is deactivated automatically. If you want continue to use the eAssistant, you may purchase an account. Decide between hourly usage charges or flat rates. For the plugin a one time fee is necessary. Find all information on our web site.

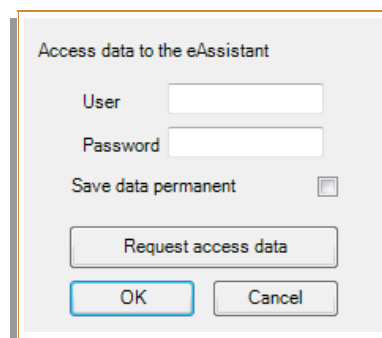

Zwei-Rollenmaß (mm)			
(spielfrei)	10.502		
(obere)	10.407		
(untere)	10.257		
Zahndickenstufte			
	7.675		
Höhe über der Zahne (mm)			

As soon as you entered the access data into the window, you are able to start all eAssistant calculation modules directly through the menu item „Calculation“. You do not need to login to the eAssistant first. The eAssistant and Autodesk Inventor will be connected automatically.



Activate the option „Save data permanent“ to save your username and password and you can open all calculation modules immediately.

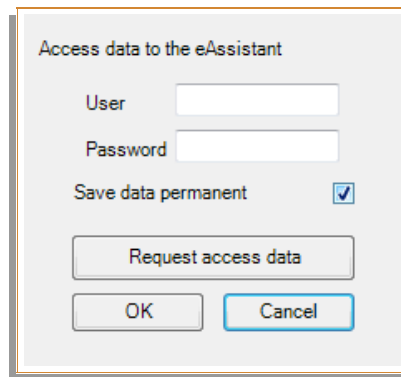

Help

Click on the menu item **Help => eAssistant help online** to start the eAssistant manual where you can find additional information on the eAssistant.

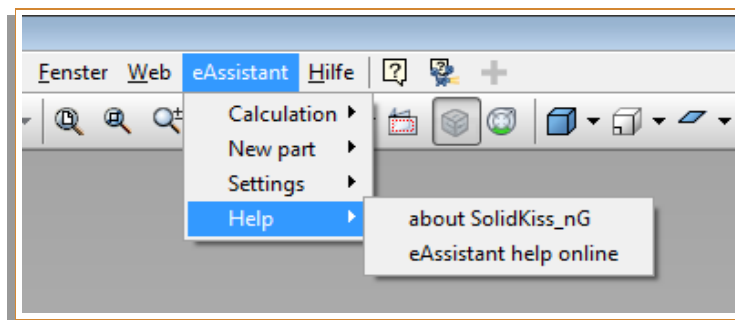

Zwei-Rollenpaar (mm)			
(spielfrei)	10.502		
(obere)	10.407		
(untere)	10.257		
Zahndickensystem	7.675		
Höhe über der Nabe (mm)			

6. Create a shaft

Based on the eAssistant calculation, shafts with an unlimited number of cylindrical and conical segments can be created as a 3D part. Once you have saved your access data, click on the menu item **eAssistant => Calculation => Shaft** to start the eAssistant module. Accomplish a shaft calculation. Click on the button **CAD => Output For CAD-PlugIn**. Click on the menu item **New part => Shaft** to create the shaft in Autodesk Inventor.

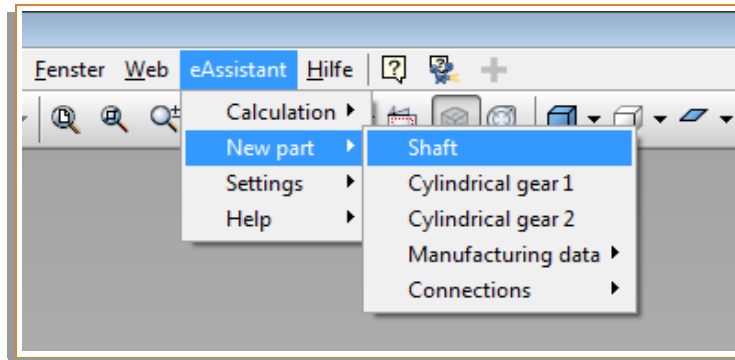

7. Create a cylindrical gear

Click on the menu item **eAssistant => Calculation => Gear => Cylindrical gear pair** and accomplish a calculation. Click on the button **CAD => Output for CAD-PlugIn**. Click on the menu item **New part => Cylindrical gear 1** or cylindrical gear 2 to create the gear in Autodesk Inventor.

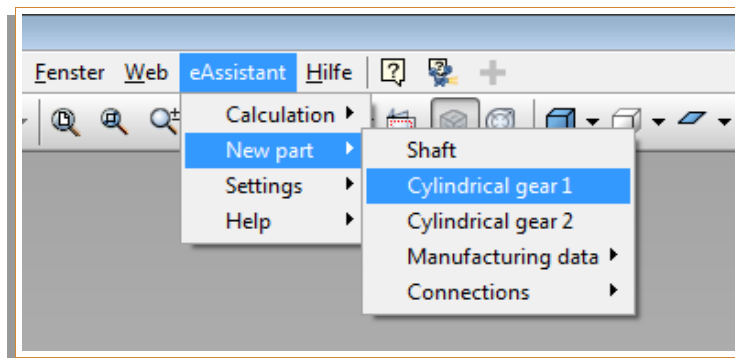

8. Create a gearing on an existing part

Create a gearing directly on an existing part.

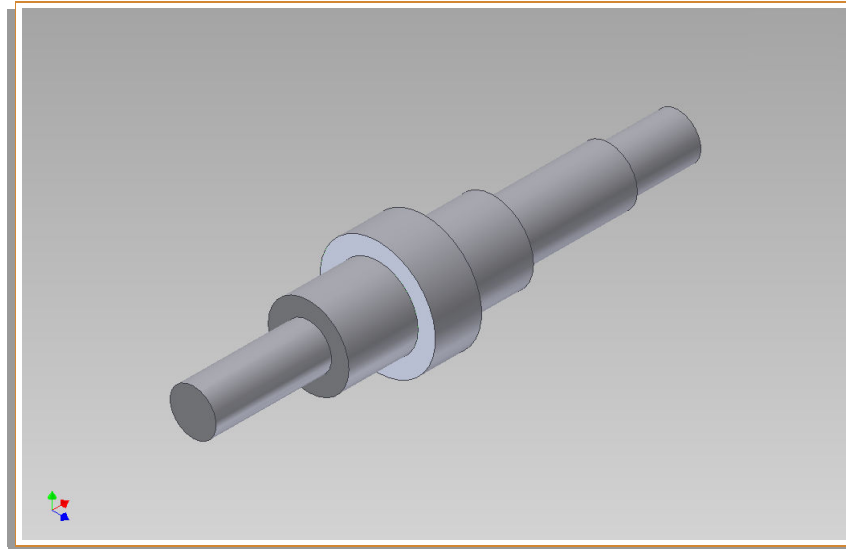

Accomplish a gear calculation in the eAssistant. Click on the button **CAD => Output for CAD-PlugIn**. Select the plane where you have to place the gearing. Select the menu item **eAssistant => New part => Cylindrical gear 1** to add the gearing to the existing part. When the dialog window for the „Runout configuration“ appears, confirm with the button „OK“.



Please note that the tip circle diameter of the spur gear and the diameter of the selected shaft segment must have the same size.

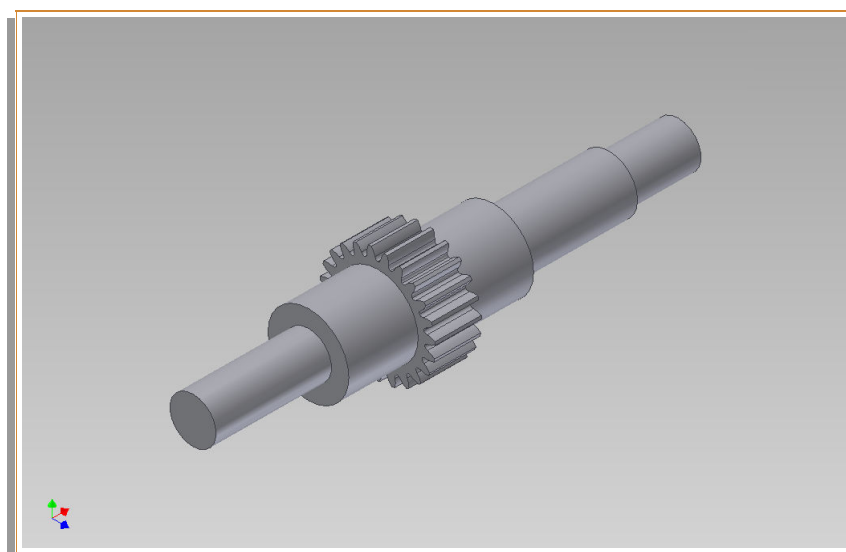

Zwei-Rollenma...			
(spielfrei)	10.502		
(obere)	10.407		
(untere)	10.357		
Zahndickenst...			
	7.675		
Höhe über der...			

9. Manufacturing data

A simple mouse-click allows you to add all necessary manufacturing data of a gear wheel to the drawing. The data is displayed as a table. Open a drawing in Autodesk Inventor. Select the menu item **New part => Manufacturing data => from current calculation => Cylindrical gear 1** to create the table.

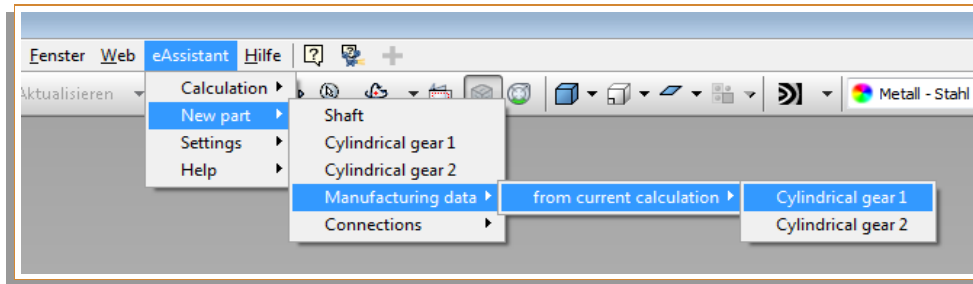

The appearance and size of that table are individually configurable. To modify the table, please open the file „SolidKiss_nG.xml“ from the program directory „eA_CADplugIn_INV“.

```

4 <DATA>
5 <INSERT row="0" col1="txt_zZahl" col2="z" col3="gear_z" col4="" visible="true" />
6 <INSERT row="0" col1="txt_facewidth" col2="m" col3="gear_b" col4="" visible="true" />
7 <INSERT row="0" col1="txt_modul" col2="mn" col3="gear_mn" col4="" visible="true" />
8 <INSERT row="0" col1="txt_beta" col2="beta" col3="gear_beta" col4="" visible="true" />
9 <INSERT row="0" col1="txt_direction_beta" col2="" col3="gear_direction" col4="" visible="true" />
10 <INSERT row="0" col1="txt_alpha" col2="alpha n" col3="gear_alpha_n" col4="" visible="true" />
11 <INSERT row="2" col1="txt_profile" col2="" col3="gear_p_name" col4="" visible="true" />
12 <INSERT row="0" col1="txt_fusshoehe" col2="h fp" col3="gear_h_fp" col4="" visible="true" />

```

Change the corresponding row, for example from visible="true" into visible="false", to hide or unhide specific table rows. In case you need more extensive customizations of the table, we can provide you a more detailed description.

10. Open a calculation of an active part

The calculation information is saved in the 3D part. The calculation, which belongs to the 3D model, is available at any time. This is also possible, if there are several different calculations in one part.

To start the calculation, which belongs to the opened part, click on the menu item **eAssistant => Calculation** and select the corresponding calculation module.

The following dialog window appears. Click on the button „Yes“ and the eAssistant opens the calculation module as well as all calculation values.

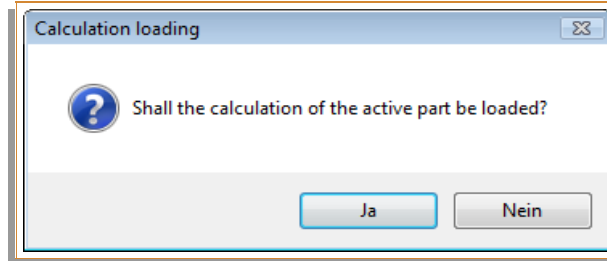

Even if there are several different gear calculations in one 3D model, you can open every calculation file again. For the gear, for example, click on the feature tree in Autodesk Inventor to select the corresponding cutout. Click on the menu item **eAssistant => Calculation** and after that click on the calculation module.

11. Add a tool runout to the 3D model

For pinion shafts you can add a tool runout to the 3D model. For this purpose, you have to specify a cutter radius. Select the menu item **eAssistant => Calculation => Gear => Cylindrical gear pair** and accomplish a spur gear calculation. Click on the button **CAD => Output for CAD-PlugIn**. Choose a plane in Autodesk Inventor and click on the menu item **eAssistant => New part => Cylindrical gear 1**. The dialog window is opened. Activate the option „Yes“ for „Run-out at start“ or „Run-out at end“. Add a cutter radius and confirm with the button „OK“.

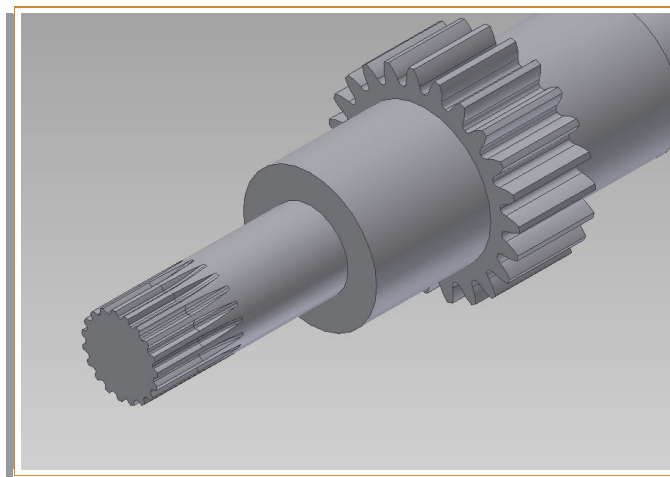
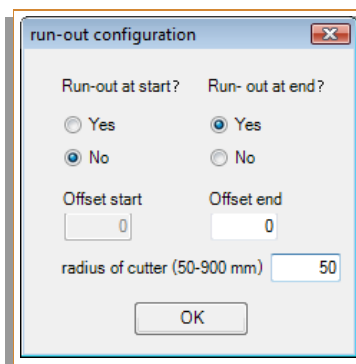

Now you can check, if the tool runout collides with the following shaft segment, so that you can correct it. If necessary, you can add a straight element by using the option „Offset“.

Sperrhochdrucklager (mm)
Zwei-Rollenmaß
-
Zahndickenstufe
-
Höhe über der Nabe (mm)

(spielfrei)	10.502
(obere)	10.407
(untere)	10.257
	7.675

We are looking for ideas, suggestions or criticism, so we would
like to know what you think.

You will always find a sympathetic ear, no matter what the problem is.

We appreciate your feedback.

GWJ Technology GmbH

Rebenring 31

D - 38106 Braunschweig, Germany

Phone: +49 (0) 531 129399-0

Fax: +49 (0) 531 129399-29

Email: info@gwj.de

Visit our web site www.eAssistant.eu to find detailed information
on the eAssistant and the CAD plugin.

Product information:

The „eAssistant“ is a product of GWJ Technology GmbH.